

## RUD INDIA CHAIN PVT. LTD.

A-68 To A-71, Osiya Mata Compound,  
Reti Bunder Road, Village Kalher,  
Tal. Bhiwandi, Dist. Thane-421302.  
Tel. : 0252-2645503  
0252-2645626 / 27 / 28  
Email : sales@rudindia.com  
Website : www.rud.com



RUD Ketten  
Rieger & Dietz GmbH u. Co. KG

## VERTICAL DRUM LIFTING TACKLE

( PRODUCT CODE: RSVDL0211 )



- ◆ For lifting steel drums of diameter 500 mm to 650 mm.
- ◆ Designed for load 500 kg with safety factor of 4.
- ◆ Minimum self weight for easy operation.
- ◆ Most user-friendly.
- ◆ Provided with positive lock in ideal condition for easy engagement.
- ◆ Provided with handles at both sides.
- ◆ Suitable for crane hook up to 5T.
- ◆ Larger jaw width to avoid drum damages.
- ◆ Load tested, powder coated with all certifications as per DIN STD.

### Dimensions in lifting position:

H = 440.0mm, L = 667.0mm, W= 120.0mm

### Dimensions in ideal position:

H = 350.0mm, L = 730.0mm, W= 120.0mm

Other product like *Drum Tilting Tackle* &  
*Horizontal Drum Lifting tackle* also available.

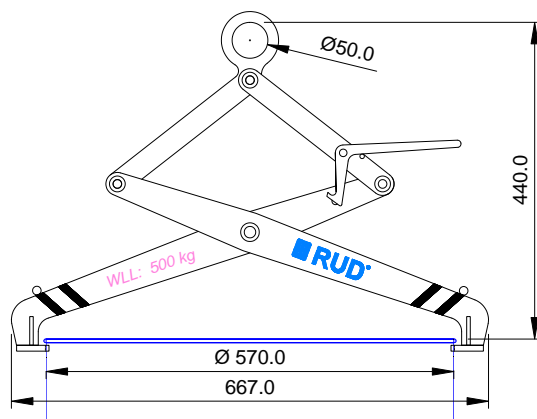

Note: For requirements other than standard sizes, please contact factory ( [sales@rudindia.com](mailto:sales@rudindia.com) )